

CORRUGATED INDUSTRY STRAPPING SOLUTIONS



Transpak Corrugated Strapping Solutions



Single Strapper



TP-702C

- High performance strapper with minimum investment
- Easy integration to every corrugated carton production line
- Smallest footprint
- Several thousands of installations around the world (connecting with leading FFG brands)
- Up to 33 bundles per minute

Strapping and Squaring System



TP-702CCQ

- The most cost-effective bundle strapper with squaring function
- Side squaring and backstop ensure better bundle shape before strapping
- Easy integration to every corrugated carton production line
- Up to 26 bundles per minute



TP-702CQ3-S

- Integrated electric-driven squaring and backstop optimize the integrity of bundles
- Smallest footprint
- Dual dispenser with auto coil change option
- 4 different ways of fast bundle size changeover
- Up to 26 bundles per minute



TP-702CQ3-T

- Designed based on TP-702CQ3-S
- One of the fastest systems designed for high capacity Flexo Folder Gluer and Casemaker
- Dual dispenser with auto coil change option
- Up to 32 bundles per minute

Strapping and Squaring System



TP-702CQ

- 4-side bundle squaring and strapping system
- Excellent side squaring, backstop, and pusher ensure the integrity of the bundle before strapping
- Easy and effortless bundle size change setup
- Up to 17 bundles per minute



TP-CIL TransCorrLiner

- Inline squaring and strapping system
- Meet the speed requirement of the fastest Flexo Folder Gluer and Casemaker
- Strapping in the flute direction
- Automatic bundle size setup in 15 seconds
- Dual dispenser with auto splicer option minimizes labor involvement
- Precise strapping position
- Up to 24 bundles per minute

Specialty Strapping Solution



TP-702CTRS

- Preferred choice for shingled-stream folder gluer output
- Ensure the best stack condition after strapping
- Protect delicate boxes from damage without sacrificing its high speed
- Simple bundle size setup via Siemens HMI
- Optimize specialty folder gluer throughput
- Up to 23 bundles per minute

Mercury TP-702C

High Speed Corrugated Strapper

TP-702C corrugated strapper is built based on Transpak's Mercury strapping head and brushless DC motor direct drive technology. High strapping speed, less maintenance requirement, innovative features, and proven reliability make it perfect for applications in sheet plants.



Main Features



Compact and Robust Strapping Head

Use the latest DC brushless motor technology to provide the highest level of accuracy and reliability. All motors are German-made. Without belts, clutches, and pulleys, its compact design greatly minimizes the numbers of moving parts and maintenance cost.



Free Access to Strap Guides (patents registered)

Unblocking the guides enables free and quick access to strap guides without using any tools. The most maintenance friendly design.



Hinged Roller Table

Easy to open the table top if maintenance is required. Ergonomic design.



Siemens PLC

Siemens PLC is the state-of-the-art controller. It is programmable and can be expanded flexibly to meet various requirements in different applications.

More Features

Auto Strap Ejector

Loop-eject clears unwanted strap automatically. Eliminate downtime.

Patented Jammed-strap Ejection Device

Make it easy to remove jammed-strap.

Full-width Pneumatic Press

Provide the highest reliability and stability for the movement of pneumatic press.

Multiple Strap Function

For single, double, continuous strapping, or transit mode.

Variable Conveyor Speed

Fully automatic operation with variable conveyor speed between 15 and 60 meters/minute.

Strap End Ejector

Eject end of strap from the inlet of strap feeding. Easy to clean the end of strap and get the machine ready for next coil of strap.

Adjustable Table Height

The table height is adjustable between 700 mm and 1000 mm.

Models

TP-702C-L arch size: 1650 mm (W) x 450mm (H)

TP-702C-M arch size: 1250 mm (W) x 450mm (H)

Options

- Siemens HMI (touch panel)
- Light tower with low strap sensor
- Foot pedal switch
- Strapping cycle counter
- Without press bar
- Uplifted support
- **Adjustable backstop**
To stop bundles at more precise position or to maintain better bundle integrity for slippery bundles.

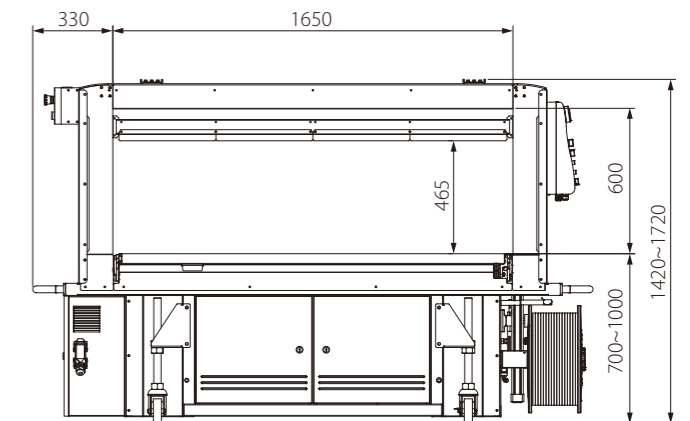
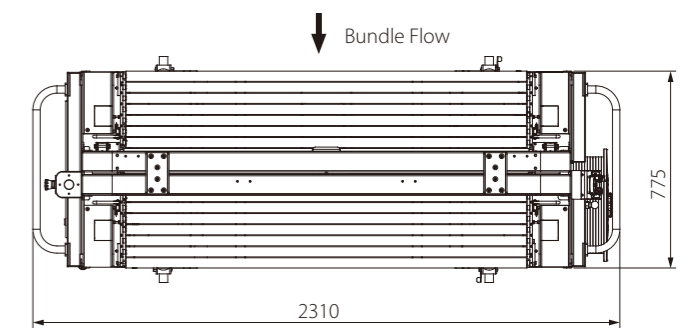

TP-702C-L

Technical Data

Capacity	Up to 33 bundles/minute (single strap) Up to 20 bundles/minute (double straps) (Model: TP-702C-L)
Strap Width	5 mm, 6 mm, or 9 mm
Tension Range	1 - 32 kg
Minimum Bundle Size	200 mm (W) x 20 mm (H) x 300 mm (L)
Bundle Weight	max 40 kg
Conveyor Speed	15 - 60 m/minute
Electrical Requirements	220V, 380V, 400V, 415V 50/60Hz 3PH

Mercury TP-702CCQ

Corrugated 3-Side Bundle Squaring and Strapping System

TP-702CCQ is built based on TP-702C high speed corrugated strapper combined with the 3-side squaring station CC-BSS. It carries all the innovative features of TP-702C. TP-702CCQ offers high strapping productivity with the most cost-effective bundle squaring solution for corrugated industry.



Main Features



Compact and Robust Strapping Head

Use the latest DC brushless motor technology to provide the highest level of accuracy and reliability. All motors are German-made. Without belts, clutches, and pulleys, its compact design greatly minimizes the numbers of moving parts and maintenance cost.



Siemens PLC

Siemens PLC is the state-of-the-art controller. It is programmable and can be expanded flexibly to meet various requirements in different applications.



3-Side Squaring Bundle Control

Excellent side squaring and backstop ensure better bundle shape before strapping.



Free Access to Strap Guides (patents registered)

Unblocking the guides enables free and quick access to strap guides without using any tools. The most maintenance friendly design.

More Features

Auto Strap Ejector

Loop-eject clears unwanted strap automatically. Eliminate downtime.

Patented Jammed-strap Ejection Device

Make it easy to remove jammed-strap.

Full-width Pneumatic Press

Provide the highest reliability and stability for the movement of pneumatic press.

Multiple Strap Function

For single, double, continuous strapping, or transit mode.

Variable Conveyor Speed

Fully automatic operation with variable conveyor speed between 15 and 60 meters/minute.

Hinged Roller Table

Easy to open the table top if maintenance is required. Ergonomic design.

Adjustable Pressure on Press and Squaring

Easy adjustment to adapt different bundle requirements.

Models

TP-702CCQ-L arch size: 1650 mm (W) x 450mm (H)

TP-702CCQ-M arch size: 1250 mm (W) x 450mm (H)

Options

- Siemens HMI (touch panel)
- Light tower with low strap sensor
- Foot pedal switch
- Strapping cycle counter
- Squaring plate extension for bundle length up to 1520 mm
- **Adjustable backstop**
To stop bundles at more precise position or to maintain better bundle integrity for slippery bundles.

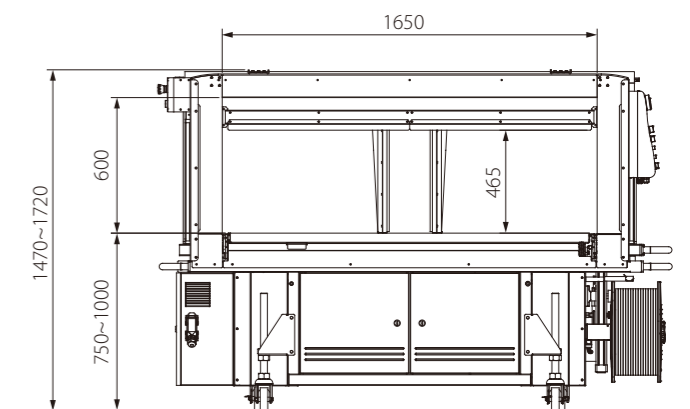
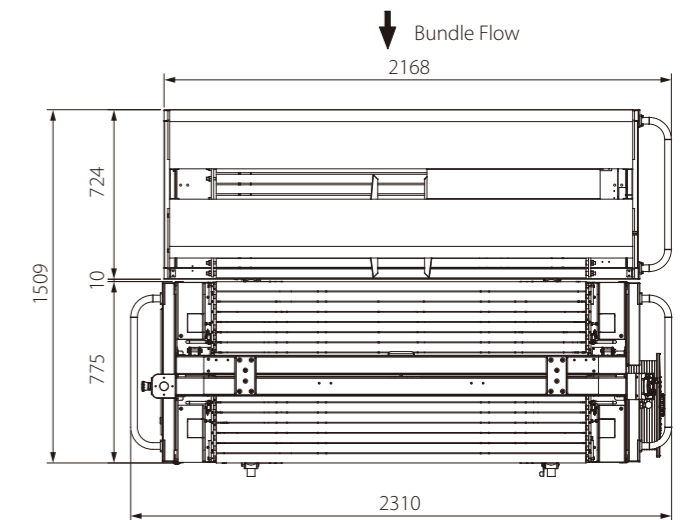

TP-702CCQ-L

Technical Data

Capacity	Up to 26 bundles/minute (single strap) Up to 20 bundles/minute (double straps) (Model: TP-702CCQ-L)
Strap Width	5 mm, 6 mm, or 9 mm
Tension Range	1 - 32 kg
Minimum Bundle Size	200 mm (W) x 20 mm (H) x 300 mm (L)
Bundle Weight	max 40 kg
Conveyor Speed	15 - 60 m/minute
Electrical Requirements	220V, 380V, 400V, 415V 50/60Hz 3PH

Mercury TP-702CQ3-S

High Speed Corrugated Strapper with Integrated Squaring System

TP-702CQ3-S is an **all-electric** high speed corrugated strapper with integrated squaring and backstop functions. It is built based on the quality proven Transpak TP-702C corrugated strapper and carries all the innovative features of the TP-702C. Motorized squaring and backstop devices provide precise bundle handling and positioning for forming perfect bundles.



Main Features



Compact and Robust Strapping Head

Use the latest brushless DC motor direct drive technology to provide the highest level of accuracy and reliability. All motors are German-made. With compact design and fewer moving parts, it can greatly minimize the maintenance cost.



Integrated 3-Side Squaring Device

The electric-driven side squaring and backstop devices optimize the integrity of bundles. Unique front and rear squaring mechanism with independent control system improves squaring performance over a wider range of bundle sizes.



Good for Small Bundle

The round belts added on rollers help to move small bundles across strapping position smoothly. It allows a minimum bundle size of width 200 mm (8") x length 250 mm (10").



Siemens PLC and HMI

Provide easy adjustments, TEACH-IN programming, and troubleshooting guides.

More Features

Automatic Bundle Size Setup System

The automatic setting mode makes the bundle size set up for TP-702CQ3-S finish in 15 seconds. It minimizes costly downtime.

All Electric Driven Design

No air consumption is required. The performance of the machine will not be restricted by the air supply.

Motorized Full-width Press

Motorized full-width press provides the highest reliability and stability of the movement. It also offers easy adjustments for different press position to optimize strapping speed.

Smallest footprint

The strapping and squaring are integrated at the same station. It optimizes the bundle condition with minimum space required.

Hinged Roller Table

Easy and effortless to open the table top for cleaning and maintenance. Ergonomic design.

Free Access to Strap Guides (patents registered)

Unblocking the guides enables free and quick access to strap guides without using any tools. The most maintenance friendly design.

Adjustable Table Height

The table height is adjustable between 700 mm and 1000 mm.

Options

• Dual dispenser with auto coil change

Machine can perform coil change automatically when the strap is running out.



- Light tower with low strap sensor
- Energy saving transit with auto sleep mode
- Floor rails
- Foot pedal switch
- Bus interface for bundle size data transfer from upstream equipment
- Uplifted support

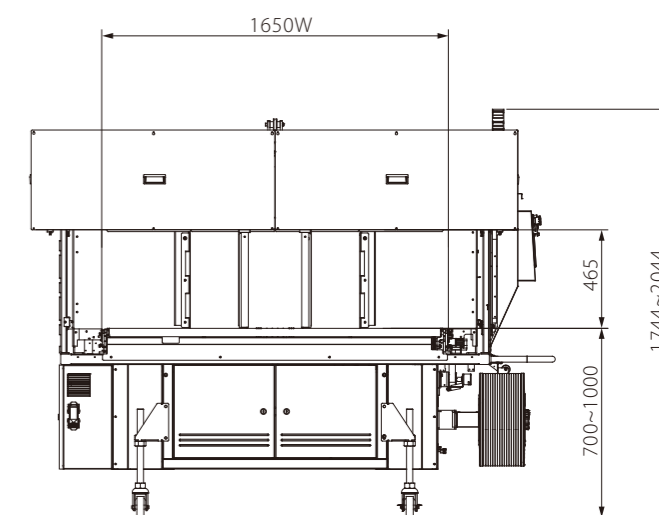
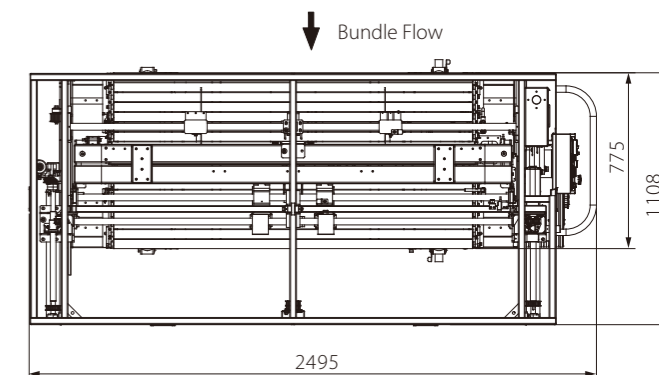

TP-702CQ3-S

Technical Data

Capacity	Up to 26 bundles/minute (single strap) Up to 13 bundles/minute (double straps)
Strap Width	5 mm, 6 mm, or 9 mm
Tension Range	1 - 32 kg
Minimum Bundle Size	200 mm (W) x 50 mm (H) x 250 mm (L)
Maximum Bundle Size	1500 mm (W) X 450 mm (H)
Bundle Weight	max 35 kg
Conveyor Speed	15 - 60 m/minute
Electrical Requirements	220V, 380V, 400V, 415V 50/60Hz 3PH

Mercury TP-702CQ3-T Tandem

High Speed Corrugated Strapper with Integrated Squaring System

TP-702CQ3-T is an **all-electric TANDEM** system of high speed corrugated strapper with integrated 3-side squaring design. Motorized squaring and backstop devices provide precise bundle handling and positioning for forming perfect bundles. The TANDEM design with the built-in program enables the system to process up to 32 bundles per minutes - one of the fastest systems designed specially for high capacity Flexo Folder Gluer and Casemaker in the industry.



Main Features



Compact and Robust Strapping Head

Use the latest brushless DC motor direct drive technology to provide the highest level of accuracy and reliability. All motors are German-made. With compact design and fewer moving parts, it can greatly minimize the maintenance cost.



Free Access to Strap Guides (patents registered)

Unblocking the guides enables free and quick access to strap guides without using any tools. The most maintenance friendly design.



Integrated 3-Side Squaring Device

The electric-driven side squaring and backstop devices optimize the integrity of bundles. Unique front and rear squaring mechanism with independent control system improves squaring performance over a wider range of bundle sizes.



Siemens PLC and HMI

Provide easy adjustments, TEACH-IN programming, and troubleshooting guides.

More Features

Automatic Bundle Size Setup System

The automatic setting mode makes the bundle size set up for TP-702CQ3-T finish in 15 seconds. It minimizes costly downtime.

All Electric Driven Design

No air consumption is required. The performance of the machine will not be restricted by the air supply.

Motorized Full-width Press

Motorized full-width press provides the highest reliability and stability of the movement. It also offers easy adjustments for different press position to optimize strapping speed.

Good for Small Bundle

The round belts added on rollers help to move small bundles across strapping position smoothly. It allows a minimum bundle size of width 200 mm (8") x length 250 mm (10").

Multiple Operation Modes

Various operation patterns give the system great flexibility to work in accordance with production requirements.

High Speed

One of the fastest strapping and squaring systems in the industry. Great for high capacity production line.

Hinged Roller Table

Easy and effortless to open the table top for cleaning and maintenance. Ergonomic design.

Options

- **Dual dispenser with auto coil change**
Machine can perform coil change automatically when the strap is running out.



- Light tower with low strap sensor
- Energy saving transit with auto sleep mode
- Floor rails
- Press roller on accumulating conveyor
- Bus interface for bundle size data transfer from upstream equipment
- Foot pedal switch
- Uplifted support

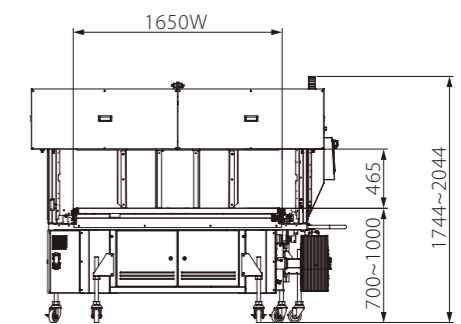
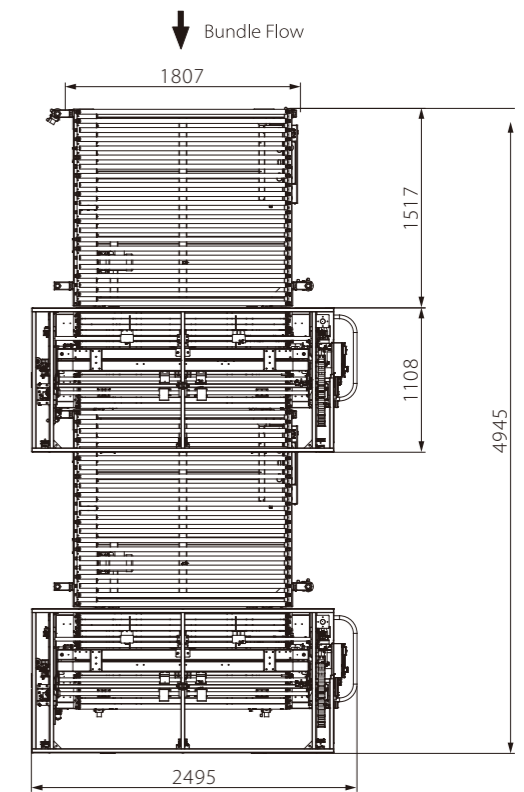

TP-702CQ3-T

Technical Data

Capacity	Up to 32 bundles/minute (single strap) Up to 26 bundles/minute (double straps)
Strap Width	5 mm, 6 mm, or 9 mm
Tension Range	1 - 32 kg
Minimum Bundle Size	200 mm (W) x 50 mm (H) x 250 mm (L)
Maximum Bundle Size	1500 mm (W) X 450 mm (H)
Bundle Weight	max 35 kg
Conveyor Speed	15 - 60 m/minute
Electrical Requirements	220V, 380V, 400V, 415V 50/60Hz 3PH

Mercury TP-702CQ

Corrugated 4-Side Bundle Squaring and Strapping System

TP-702CQ is built based on TP-702C high speed corrugated strapper combined with the 4-side squaring station C1-BQ. It carries all the innovative features of TP-702C. The backstop, pusher, and side squaring altogether provide the precise bundle control and assure the bundle integrity during the strapping cycle. Easy bundle size change setup eliminates the downtime and makes the production more efficient. Truly user friendly machine for your Casemaking and Flexo Folder Gluer line.



Main Features



Compact and Robust Strapping Head

Use the latest brushless DC motor technology to provide the highest level of accuracy and reliability. All motors are German-made. Without belts, clutches, and pulleys, its compact design greatly minimizes the numbers of moving parts and maintenance cost.



Siemens PLC and HMI

Siemens PLC is the state-of-the-art controller. It is programmable and can be expanded flexibly to meet various requirements in different applications. The Siemens HMI (touch panel) provides easy adjustments, operating instructions, and troubleshooting guides.



Free Access to Strap Guides (patents registered)

Unblocking the guides enables free and quick access to strap guides without using any tools. The most maintenance friendly design.



4-Side Squaring Bundle Control

Excellent side squaring, backstop, and pusher ensure the integrity of the bundle before strapping.

More Features

Auto Strap Ejector

Loop-eject clears unwanted strap automatically. Eliminate downtime.

Patented Jammed-strap Ejection Device

Make it easy to remove jammed-strap.

Full-width Pneumatic Press

Provide the highest reliability and stability for the movement of pneumatic press.

Hinged Roller Table

Easy to open the table top if maintenance is required. Ergonomic design.

Multiple Strap Function

For single, double, continuous strapping, or transit mode.

Variable Conveyor Speed

Fully automatic operation with variable conveyor speed between 15 and 60 meters/minute.

Strap End Ejector

Eject end of strap from the inlet of strap feeding. Easy to clean the end of strap and get the machine ready for next coil of strap.

Adjustable Pressure on Press and Squaring

Easy adjustment to adapt different bundle requirements.

Adjustable Table Height

The table height is adjustable between 700 mm and 1000 mm.

Models

TP-702CQ-L arch size: 1650 mm (W) x 450mm (H)

TP-702CQ-M arch size: 1250 mm (W) x 450mm (H)

Options

- Light tower with low strap sensor
- Foot pedal switch

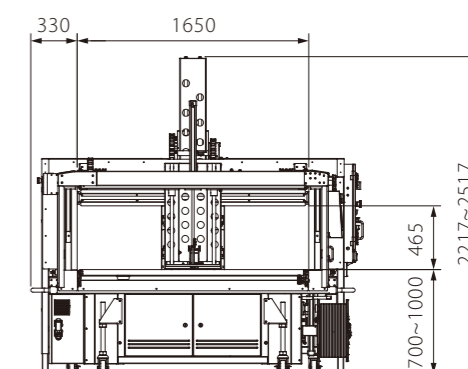
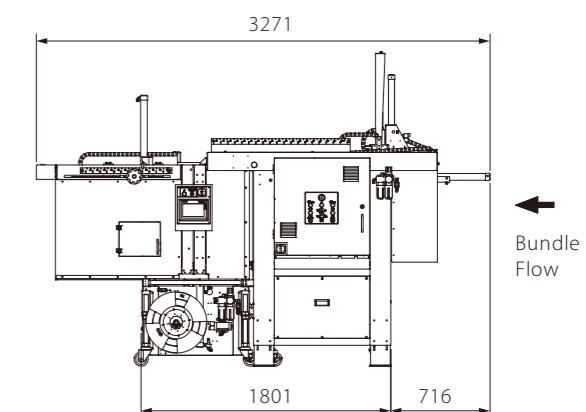
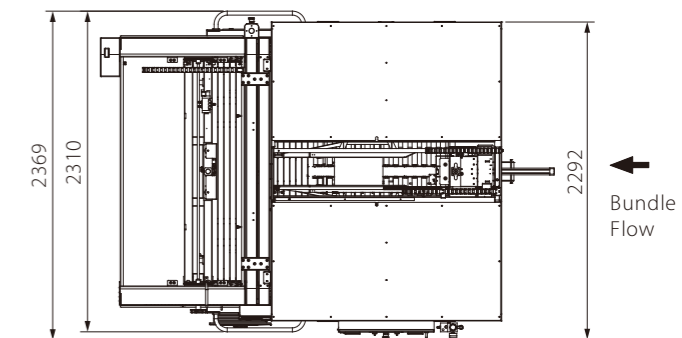

TP-702CQ-L

Technical Data

Capacity	Up to 17 bundles/minute (single strap) Up to 13 bundles/minute (double straps) (Model: TP-702CQ-L)
Strap Width	5 mm, 6 mm, or 9 mm
Tension Range	1 - 32 kg
Minimum Bundle Size	200 mm (W) x 50 mm (H) x 350 mm (L)
Bundle Weight	max 35 kg
Conveyor Speed	15 - 60 m/minute
Electrical Requirements	220V, 380V, 400V, 415V 50/60Hz 3PH

TransCorrLiner TP-CIL

Inline Squaring and Strapping System

TransCorrLiner TP-CIL is a high speed corrugated inline squaring and strapping system which meets the speed requirement of the fastest Flexo Folder Gluer and Casemaker. TP-CIL uses the latest brushless DC motor direct drive technology in sealing head, needle, squaring devices, and off-center strapping to provide the highest level of reliability and durability. In addition, the intelligent self-positioned pusher detects bundle length automatically to streamline production process and increase strapping speed.



Main Features



Compact and Robust Strapping Head

Use the latest brushless DC motor direct drive technology in sealing head, needle, squaring devices, and off-center strapping to provide the highest level of accuracy and reliability. All motors are German-made.



Intelligent Pusher Optimizes Speed (patents registered)

The intelligent self-positioned pusher detects bundle length and height automatically. It streamlines production process and increases strapping speed.



Automatic Bundle Size Setup System

The automatic setting mode makes TP-CIL fast set-up for bundle size change in 15 seconds. It minimizes costly downtime.



Independent Controlled Conveyor

Built-in independent conveyor at the entrance eliminates bundle jams.

More Features

Strapping in the Flute Direction

Applying strapping in the transport direction, in line with the flutes, typically reduces strap consumption and also ensures the strap is applied at the optimum position.

Siemens PLC and HMI

Provide easy adjustments, TEACH-IN programming, simplified set-up, and troubleshooting guides.

Off-center Strapping

The strapping position is adjustable for applying perfect strapping on complex bundles sizes and formats.

Hot Standby Mode (Twin head model only)

In single strap applications, the second head stays in hot standby mode, and can be activated in seconds automatically when needed for eliminating downtime.

Drape-Strap Feeding System

Needle type drape-strap feeding design allows TP-CIL to use economical PP strapping. Maximize cost efficiency.

Dual Channel E-stop

This provides an additional emergency stop circuit loop to ensure the E-stop operation if either loop is invalid, fulfilling a higher-level safety requirement.

Stack Sizes

Models	Width A (mm)		Length B (mm)		Height C (mm)	
	min	max	min	max	min	max
TP-CIL-13S	240	1300	180	1300	50	350
TP-CIL-13T	450	1300	180	1300	50	350
TP-CIL-16S	270	1600	180	1600	50	350
TP-CIL-16T	450	1600	180 <td 1600	50	350	

S(single) : one strapping head
T(twin) : two strapping heads

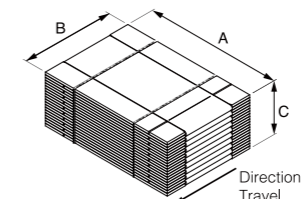

Options

- Powered alignment device
- **Dual dispenser with auto splicer**
- Air conditioner for control box
- Belt driven conveyor for the last bundle
- Energy saving transit with auto sleep mode
- Bus interface for bundle size data transfer from upstream equipment
- Gravity wheel conveyor

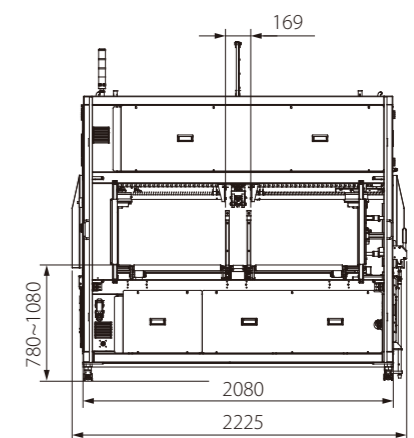
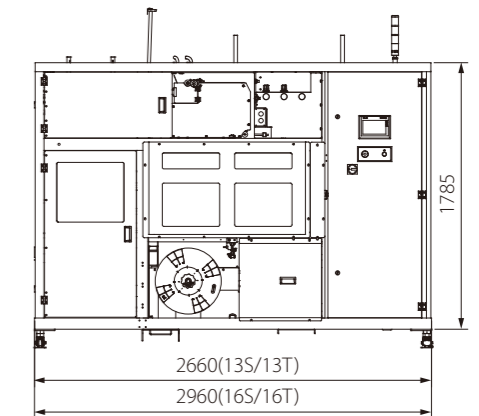
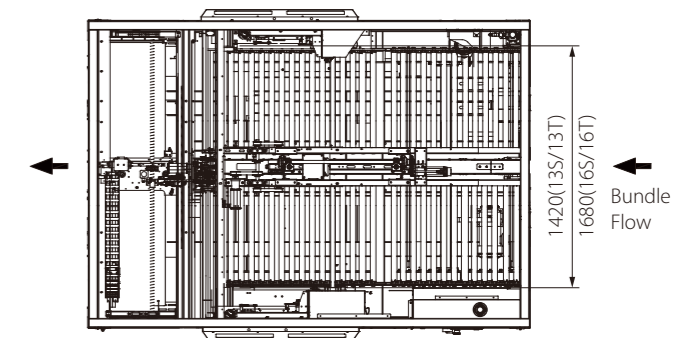

TP-CIL

Technical Data

Capacity	Up to 24 bundles/minute (Model: TP-CIL-13S & TP-CIL-13T)
Strap Width	5 mm, 6 mm, 8 mm, or 9 mm
Tension Range	1 - 20 kg
Bundle Weight	max 30 kg
Conveyor Height	780 - 1080 mm
Conveyor Speed	30 - 70 m/minute
Electrical Requirements	220V, 380V, 400V, 415V 50/60Hz 3PH

Mercury TP-702CTRS

High Speed Strapper for Specialty Folder Gluer Boxes

TP-702CTRS is designed to strap specialty boxes, including crash lock boxes, four corner tray, and other folded type boxes from shingled-stream folder gluer output. The clever side-pusher and backstop designs ensure of the best stack condition after strapping and protect delicate boxes from damage without sacrificing its high speed. TP-702CTRS is an efficient squaring and strapping solution for specialty folder gluer products.



Main Features



Compact and Robust Strapping Head

Use the latest brushless DC motor direct drive technology to provide the highest level of accuracy and reliability. All motors are German-made. With compact design and fewer moving parts, it can greatly minimize the maintenance cost.



Easy Maintenance

The strapping unit and the conveying unit are independently designed. The strapping unit can be quickly and easily pulled out for the convenience of service and maintenance.



Siemens PLC and HMI

Provide easy adjustments, TEACH-IN programming, and troubleshooting guides.



Ascending Backstop with Sensor

The backstop with sensor ascends inclinedly. It prevents damage to stacks, and ensures the stack integrity and precise strapping position.

More Features

Quick and Effortless Changeover

The positioning of the backstop, side pusher, and all other settings can be easily adjusted through Siemens HMI (touch panel) near operator position. Convenient, quick, and effortless.

Free Access to Strap Guides (patents registered)

Unlocking the guides enables free and quick access to strap guides without using any tools. The most maintenance friendly design.

Auto Strap Ejector

Loop-eject clears unwanted strap automatically. Eliminate downtime.

Strap End Ejector

Eject end of the strap from the inlet of strap feeding. Easy to remove the end of the strap and get the machine ready for the next coil of strap.

Sensor Controlled Heater

The fast heating mechanism is sensor controlled assuring consistent and high sealing efficiency.

Adjustable Table Height

The table height is adjustable between 700 mm and 900 mm.

Options

- Light tower with low strap sensor
- Foot pedal switch
- Uplifted support
- **Powered top conveyor**
Assisting the transport of unstable stacks and ensuring the perfect stack condition during transportation.



Additional backstop

Precisely determine 2 strapping positions.

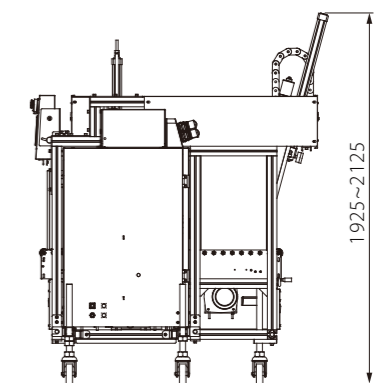
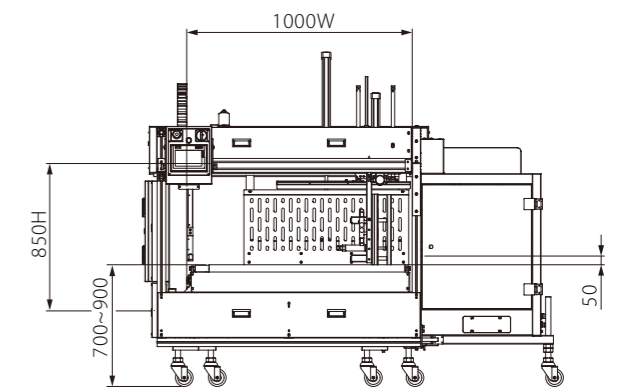
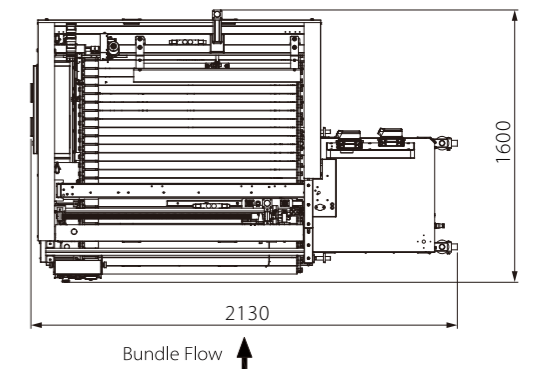

TP-702CTRS (arch width 1000 mm)

Technical Data

Capacity	Up to 23 bundles/minute (single strap)																
Strap Width	5 mm, 6 mm, 9 mm, or 12 mm																
Tension Range	1 - 32 kg (for 5 mm, 6 mm, or 9 mm) 1 - 55 kg (for 12mm)																
Maximum Bundle Size (mm)	<table border="1"> <thead> <tr> <th>arch width</th> <th>width</th> <th>height</th> <th>length</th> </tr> </thead> <tbody> <tr> <td>1000</td> <td>950</td> <td>x 400</td> <td>x 1300</td> </tr> <tr> <td>1300</td> <td>1250</td> <td>x 400</td> <td>x 1300</td> </tr> <tr> <td>1600</td> <td>1550</td> <td>x 400</td> <td>x 1300</td> </tr> </tbody> </table>	arch width	width	height	length	1000	950	x 400	x 1300	1300	1250	x 400	x 1300	1600	1550	x 400	x 1300
arch width	width	height	length														
1000	950	x 400	x 1300														
1300	1250	x 400	x 1300														
1600	1550	x 400	x 1300														
Bundle Weight	max 25 kg																
Conveyor Speed	24 - 60 m/minute																
Electrical Requirements	220V, 380V, 400V, 415V 50/60Hz 3PH																

Auxiliary Equipment

C-BT

Bundle Turner for Corrugated Carton

C-BT Bundle Turner is designed for turning the bundles by 90 degrees to optimize production line configuration. It's also an ideal solution to change the strapping direction on the bundles when placed prior to strapping system.

- Table height is adjustable between 700 mm and 1000 mm
- Minimum bundle size:
200 mm(W) x 20 mm(H) x 300 mm(L)
- Table size:
C-BT-L 1662 mm(W) x 2400 mm(D)
C-BT-M 1662 mm(W) x 1880 mm(D)



C-AC

Upstream Accumulating Conveyor with Press Roller

C-AC is an accumulating conveyor with press roller designed specially for corrugated industry. It functions as an accumulation/buffer zone between strapping machine and upstream equipment, which allows bundles to enter strapping machine one at a time.

- Table height is adjustable between 780 mm and 1080 mm
- Minimum bundle size:
180 mm(W) x 50 mm(H) x 180 mm(L)



C-CV

Accumulating Conveyor

C-CV is an accumulating conveyor designed specially for corrugated industry. It functions as an accumulation/buffer zone between strapping machine and upstream equipment, which allows bundles to enter strapping machine one at a time.

- Table height is adjustable between 700 mm and 1000 mm
- Minimum bundle size:
200 mm(W) x 50 mm(H) x 250 mm(L)



More Machines for Corrugated Industry

Mercury TP-702

Automatic Strapping Machine

Mercury TP-702 is an innovative world-class high speed automatic strapping machine. It is suitable for 5 mm, 6 mm, 9 mm, or 12 mm PP strapping. It equips with all industrial standard features and creative user friendly designs. Mercury TP-702 offers the most optimal performance, highest speed, easiest maintenance, and the most cost effective solution in its class today.

- High value-added machine
- Speed up to **65** straps per minute
- Smart control panel with LCD display
- Waist-high auto strap feeding
- Sensor controlled heater assures consistent and high sealing efficiency
- Various arch sizes are available



Mercury TP-702P

Automatic Strapping Machine with Dual Pneumatic Press

Mercury TP-702P (with dual press) is ideal to strap compressible material such as corrugated papers, paper sheets, corrugated boxes, etc.

- Equipped with dual press
- Same mechanical strapping head as Mercury TP-702
- Free access to strap guides (patents registered)
- Speed up to 47 straps per minute
- Various arch sizes are available



Battery Powered Tools

Helios H-45L

- Bosch battery and charger
- Friction weld sealing
- Max. tension force **250 kg**
- Strap width: 9 mm,
11 mm-13 mm,
15 mm-16 mm



Kronos H-46

- Bosch battery and charger
- Friction weld sealing
- Digital touch panel
- Max. tension force **400 kg**
- Strap width:
H-46A for 11 mm-13 mm,
15 mm-16 mm
H-46B for 15 mm-16 mm,
19 mm



**Offer the Maximum Value
with the Minimum Cost.**

Always More than You Expect.

